



## Accessories for Ex AZM 415 / Ex AZP 415

### Flexible actuator AZM 415-B3

Material no.: 1171892 (material no. old: 01.08.0177)

#### Product features



- Especially suitable for sliding and hinged guards
- For very small actuating radii via the narrow edge of the actuator
- Actuating radius adjustable using a hexagonal key wrench

#### Notes

- Removal of the actuator can be prevented by fitting dowel pins in the holes provided.
- The distance between the flange of the actuator and the switch enclosure must be less than 3 mm when the actuator is inserted.

#### Dimensions

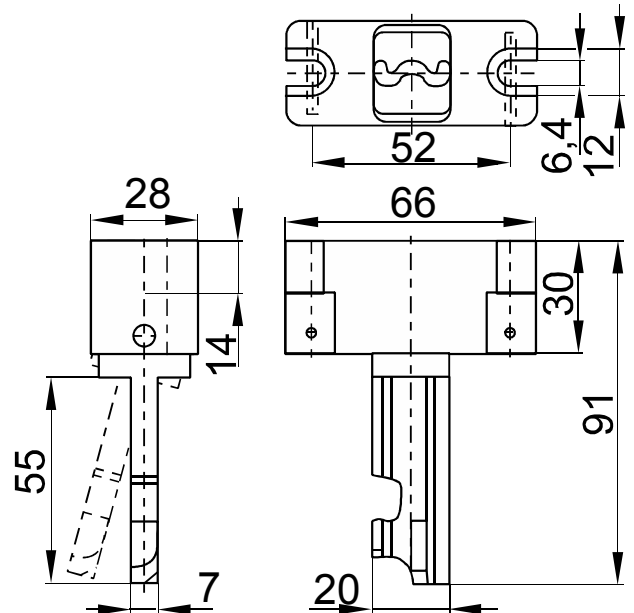

#### Technical data

Shearing force  
25,000 N

Weight  
165 g

Actuating radius  
min. 250 mm

#### Actuating radius

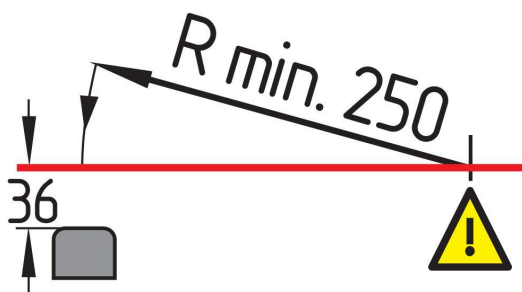

Attention! 36 mm must be referred to the surface of the enclosure and not to the inserted actuator!

#### Distance between actuator/enclosure

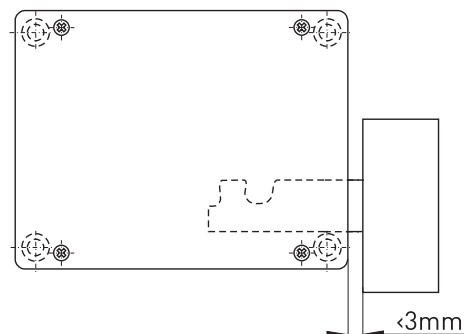

Errors and omissions excepted.



Accessories for Ex AZM 415 / Ex AZP 415  
Flexible actuator AZM 415-B3  
Material no.: 1171892 (material no. old: 01.08.0177)

## Adjustment

---

