

SmartReflect Light barriers

FNDH 14G6903/KS34A/IO

dimension drawing

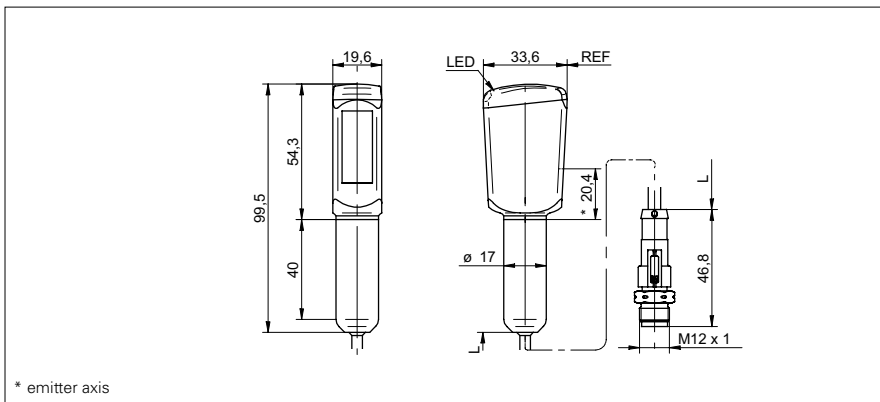

general data

type	light barrier
special type	Hygiene design
version	Foil detection
light source	pulsed red LED
background position Sde	200 ... 800 mm on V4A
minimal signal attenuation	12 %
alignment / soiled lens indicator	flashing light indicator
power on indication	LED green
output indicator	LED red
sensitivity adjustment	IO-Link
sensing distance adjustment	Teach-in
wave length	660 nm
Approvals/certificates	Ecolab EHEDG

photo



electrical data

response time / release time	< 1,8 ms
voltage supply range +Vs	10 ... 30 VDC
current consumption max. (no load)	40 mA
current consumption typ.	35 mA
voltage drop Vd	< 2 VDC
output function	light / dark operate
output circuit	push-pull
output current	< 100 mA
short circuit protection	yes
reverse polarity protection	yes

mechanical data

width / diameter	19,6 mm
height / length	54,3 mm
depth	33,6 mm
type	rectangular
housing material	stainless steel 1.4404 (V4A), PA12 ; LSR
front (optics)	PMMA
connection types	flylead connector M12, L=300 mm

connection diagram

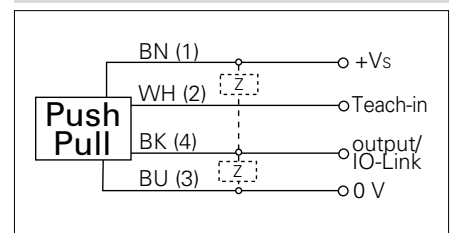

IO-Link

proTect⁺

- Sensor FDA compliant, EHEDG certified and Ecolab approved
- IO-Link: output signal, service status, object presence
- sensitivity adjustable: via Teach-in wire input
- LSR = Liquid Silicon Rubber

SmartReflect Light barriers**FNDH 14G6903/KS34A/IO****ambient conditions**

operating temperature	-30 ... +60 °C
protection class	IP 68/69K & proTect+
storage temperature	-30 ... +70 °C